

**PR**  
electronics



**6 3 3 1**

**2-Wire Programmable  
Transmitter**

No. 6331V105-UK  
From ser. no. 079224041

**ATEX**  

- DK** ▶ PR electronics A/S tilbyder et bredt program af analoge og digitale signalbehandlingsmoduler til industriel automation. Programmet består af Isolatorer, Displays, Ex-barrierer, Temperaturtransmittere, Universaltransmittere mfl. Vi har modulerne, du kan stole på i selv barske miljøer med elektrisk støj, vibrationer og temperaturudsving, og alle produkter opfylder de strengeste internationale standarder. Vores motto »Signals the Best« er indbegrebet af denne filosofi - og din garanti for kvalitet.
- UK** ▶ PR electronics A/S offers a wide range of analog and digital signal conditioning devices for industrial automation. The product range includes Isolators, Displays, Ex Interfaces, Temperature Transmitters, and Universal Modules. You can trust our products in the most extreme environments with electrical noise, vibrations and temperature fluctuations, and all products comply with the most exacting international standards. »Signals the Best« is the epitome of our philosophy - and your guarantee for quality.
- FR** ▶ PR electronics A/S offre une large gamme de produits pour le traitement des signaux analogiques et numériques dans tous les domaines industriels. La gamme de produits s'étend des transmetteurs de température aux afficheurs, des isolateurs aux interfaces SI, jusqu'aux modules universels. Vous pouvez compter sur nos produits même dans les conditions d'utilisation sévères, p.ex. bruit électrique, vibrations et fluctuations de température. Tous nos produits sont conformes aux normes internationales les plus strictes. Notre devise »SIGNALS the BEST« c'est notre ligne de conduite - et pour vous l'assurance de la meilleure qualité.
- DE** ▶ PR electronics A/S verfügt über ein breites Produktprogramm an analogen und digitalen Signalverarbeitungsgeräte für die industrielle Automatisierung. Dieses Programm umfasst Displays, Temperaturtransmitter, Ex- und galvanische Signaltrenner, und Universalgeräte. Sie können unsere Geräte auch unter extremen Einsatzbedingungen wie elektrisches Rauschen, Erschütterungen und Temperaturschwingungen vertrauen, und alle Produkte von PR electronics werden in Übereinstimmung mit den strengsten internationalen Normen produziert. »Signals the Best« ist Ihre Garantie für Qualität!

# 2-WIRE PROGRAMMABLE TRANSMITTER

## PRetrans 6331

### CONTENTS

Application.....	2
Technical characteristics.....	2
Mounting / installation .....	2
Applications.....	3
Order: 6331.....	4
Electrical specifications.....	4
Connections .....	8
Block diagram.....	10
Programming .....	11
Appendix .....	12
ATEX Installation Drawing - 6331A .....	13
ATEX Installation Drawing - 6331B .....	14

# 2-WIRE PROGRAMMABLE TRANSMITTER

## PRetrans 6331

- *RTD, TC, Ohm, or mV input*
- *Extremely high measurement accuracy*
- *Galvanic isolation*
- *Programmable sensor error value*
- *1- or 2-channel version*

### Application

- Linearised temperature measurement with Pt100...Pt1000, Ni100...Ni1000, or TC sensor.
- Conversion of linear resistance variation to a standard analogue current signal, for instance from valves or Ohmic level sensors.
- Amplification of a bipolar mV signal to a standard 4...20 mA current signal.

### Technical characteristics

- Within a few seconds the user can program PR6331 to measure temperatures within all ranges defined by the norms.
- The RTD and resistance inputs have cable compensation for 2-, 3- and 4-wire connection.
- Continuous check of vital stored data for safety reasons.

### Mounting / installation

- Mounted vertically or horizontally on a DIN rail. Using the 2-channel version up to 84 channels per metre can be mounted.
- **NB:** As Ex barrier for 6331B we recommend 5401B, 5114B, or 5116B.

## APPLICATIONS

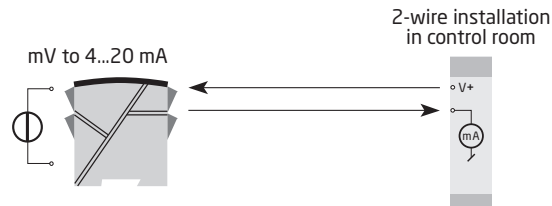
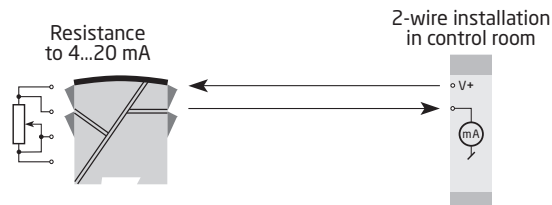
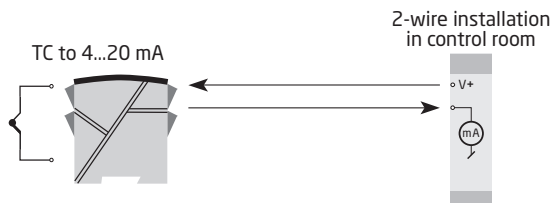
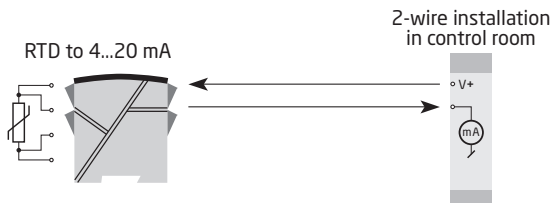

Order: 6331

Type	Version	Galvanic isolation	Channels
6331	Standard : A ATEX Ex : B	1500 VAC : 2	Single : A Double : B

\*NB! Please remember to order CJC connectors type 5910 / 5910Ex (channel 1) and 5913 / 5913Ex (channel 2) for TC inputs with an internal CJC.

## Electrical specifications

### Specifications range:

-40°C to +60°C

### Common specifications:

Supply voltage, DC

Standard..... 7.2...35 V

ATEX Ex..... 7.2...30 VDC

Internal consumption ..... 0.17...0.8 W

Voltage drop ..... 7.2 VDC

Isolation voltage, test / operation ..... 1.5 kVAC / 50 VAC

Isolation voltage, channel 1 / channel 2:

Standard..... 3.75 kVAC

ATEX Ex..... 1500 VAC

Warm-up time..... 5 min.

Communications interface ..... Loop Link

Signal / noise ratio ..... Min. 60 dB

Response time (programmable)..... 1...60 s

EEPROM error check ..... < 3.5 s

Signal dynamics, input..... 20 bit

Signal dynamics, output ..... 16 bit

Calibration temperature ..... 20...28°C

Accuracy, the greater of general and basic values:

General values		
Input type	Absolute accuracy	Temperature coefficient
All	≤ ±0.05% of span	≤ ±0.01% of span / °C

Basic values		
Input type	Basic accuracy	Temperature coefficient
RTD	$\leq \pm 0.2^{\circ}\text{C}$	$\leq \pm 0.01^{\circ}\text{C}/^{\circ}\text{C}$
Lin. R	$\leq \pm 0.1 \Omega$	$\leq \pm 10 \text{ m}\Omega / ^{\circ}\text{C}$
Volt	$\leq \pm 10 \mu\text{V}$	$\leq \pm 1 \mu\text{V} / ^{\circ}\text{C}$
TC type: E, J, K, L, N, T, U	$\leq \pm 1^{\circ}\text{C}$	$\leq \pm 0.05^{\circ}\text{C} / ^{\circ}\text{C}$
TC type: B, R, S, W3, W5, LR	$\leq \pm 2^{\circ}\text{C}$	$\leq \pm 0.2^{\circ}\text{C} / ^{\circ}\text{C}$

EMC immunity influence .....	$< \pm 0.5\%$ of span
Extended EMC immunity: NAMUR NE 21, A criterion, burst .....	$< \pm 1\%$ of span

Effect of supply voltage variation .....	$< 0.005\%$ of span / VDC
Max. wire size .....	1 x 1.5 mm <sup>2</sup> stranded wire
Humidity .....	$< 95\%$ RH (non-cond.)
Dimensions .....	109 x 23.5 x 104 mm
Protection degree .....	IP20
Weight (1 / 2 channels) .....	145 / 185 g

#### Electrical specifications, input:

Max. offset ..... 50% of selec. max. value

#### RTD and linear resistance input:

RTD type	Min. value	Max. value	Min. span	Standard
Pt100	-200°C	+850°C	25°C	IEC 60751
Ni100	-60°C	+250°C	25°C	DIN 43760
Lin. R	0 Ω	5000 Ω	30 Ω	-----

Cable resistance per wire (max.) .....	5 Ω
Sensor current .....	Nom. 0.2 mA
Effect of sensor cable resistance (3- / 4-wire) .....	$< 0.002 \Omega/\Omega$
Sensor error detection .....	Yes

**TC input:**

Type	Min. temperature	Max. temperature	Min. span	Standard
B	+400°C	+1820°C	100°C	IEC584
E	-100°C	+1000°C	50°C	IEC584
J	-100°C	+1200°C	50°C	IEC584
K	-180°C	+1372°C	50°C	IEC584
L	-100°C	+900°C	50°C	DIN 43710
N	-180°C	+1300°C	50°C	IEC584
R	-50°C	+1760°C	100°C	IEC584
S	-50°C	+1760°C	100°C	IEC584
T	-200°C	+400°C	50°C	IEC584
U	-200°C	+600°C	50°C	DIN 43710
W3	0°C	+2300°C	100°C	ASTM E988-90
W5	0°C	+2300°C	100°C	ASTM E988-90
LR	-200°C	+800°C	50°C	GOST 3044-84

Cold junction compensation ..... <  $\pm 1.0^{\circ}\text{C}$ 

Sensor error detection ..... Yes

Sensor error current:

When detecting ..... Nom. 33  $\mu\text{A}$ Else ..... 0  $\mu\text{A}$ **Voltage input:**

Measurement range ..... -12..800 mV

Min. span ..... 5 mV

Input resistance ..... 10 M $\Omega$ **Output:****Current output:**

Signal range ..... 4..20 mA

Min. signal range ..... 16 mA

Updating time ..... 440 ms

Output signal at EEprom error .....  $\leq 3.5$  mALoad resistance .....  $\leq (V_{\text{supply}} - 7.2) / 0.023$  [ $\Omega$ ]Load stability ..... <  $\pm 0.01\%$  of span / 100  $\Omega$ **Sensor error detection:**

Programmable ..... 3.5..23 mA

Namur NE43 Upscale ..... 23 mA

Namur NE43 Downscale ..... 3.5 mA

Of span = Of the presently selected range



**Ex approval - 6331A:**

KEMA 10ATEX0005 X.....	II 3 G Ex nA [nL] IIC T6...T4
	II 3 G Ex nL IIC T6...T4
	II 3 G Ex nA [ic] IIC T6...T4
	II 3 G Ex ic IIC T6...T4
ATEX Installation Drawing No.....	6331QA02

**Ex / I.S. approval - 6331B:**

KEMA 06ATEX0115.....	 II 1 G Ex ia IIC T6...T5
Max. ambient temperature for T5 .....	60°C
Max. ambient temperature for T6 .....	40°C
ATEX, applicable in zone.....	0, 1, or 2
ATEX Installation Drawing No.....	6331QA01

**GOST R approval:**

VNIIM & VNIIFTRI, Cert. no. .... See [www.preelectronics.com](http://www.preelectronics.com)

**Observed authority requirements:**

EMC 2004/108/EC .....

ATEX 94/9/EC.....

**Standard:**

EN 61326-1

EN 60079-0, EN 60079-11,

EN 60079-15, EN 60079-26

# CONNECTIONS

Inputs:

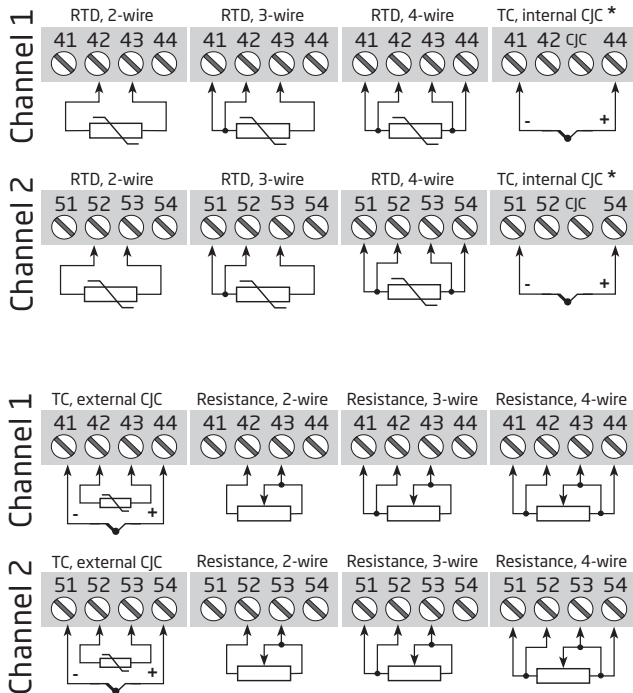

## CONNECTIONS

Inputs:

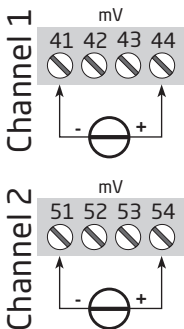

Outputs:

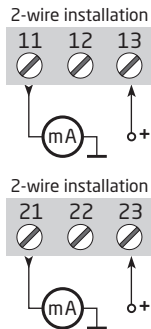

# BLOCK DIAGRAM

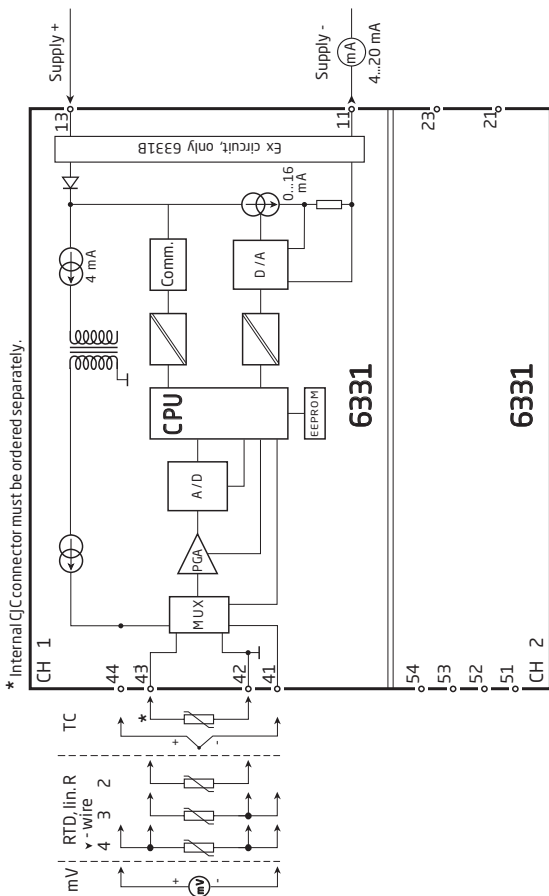

# PROGRAMMING

- Loop Link is a communications interface that is needed for programming PRetrans 6331.
- For programming please refer to the drawing below and the help functions in PReset.
- When communicating with non-installed modules, connectors 11, 12, 13 (channel 1) and 21, 22, 23 (channel 2) can be dismantled in the safe area to connect the terminals of the communications interface to the pins.
- Loop link is not approved for communication with modules installed in hazardous (Ex) areas

## Order: Loop Link

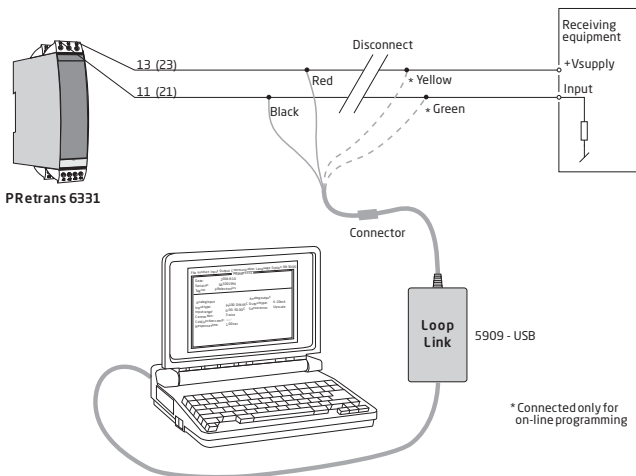

# APPENDIX

**ATEX Installation Drawing - 6331A**

**ATEX Installation Drawing - 6331B**

## ATEX Installation drawing

For safe installation of 6331A or the 6334A the following must be observed. The module shall only be installed by qualified personnel who are familiar with the national and international laws, directives and standards that apply to this area.

Year of manufacture can be taken from the first two digits in the serial number.

ATEX Certificate KEMA 10ATEX 0005X

Marking



II 3 G Ex nA [nL] IIC T6..T4  
II 3 G Ex nL IIC T6..T4

II 3 G Ex nA [ic] IIC T6..T4  
II 3 G Ex ic IIC T6..T4

Standards

EN 60079-0 : 2006, EN 60079-11 : 2007, EN 60079-15 : 2005

T6: -40°C to 60 °C  
T4: -40°C to 85 °C

**Terminal:**

**41,42,43,44 /  
51,52,53,54**

Ex nA [nL]

Uo: 9.6 VDC

Io: 25 mA

Po: 60 mW

Lo: 33 mH

Co: 2.4µF

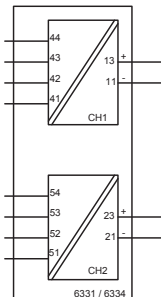

Hazardous Area Zone 2

**Terminal:**

**11-13 / 21-23**

Ex nA

U ≤ 35 VDC

I = 4 - 20 mA

Ex nL or Ex ic

Ui = 35 VDC

Li = 10 µH

Ci = 1.0 nF

### Special conditions for safe use.

For use in a potentially explosive atmosphere of flammable gasses, vapours or mists, the transmitter shall be mounted in an enclosure providing a degree of protection of at least IP54 in accordance to EN60529.

## ATEX Installation drawing



### 6331

For safe installation of 6331Bxx or 6334Bxx the following must be observed. The module shall only be installed by qualified personnel who are familiar with the national and international laws, directives and standards that apply to this area.

Year of manufacture can be taken from the first two digits in the serial number.

ATEX Certificate KEMA 06ATEX 0115

Marking  II 1 G Ex ia IIC T6..T5

Standards EN 60079-0 : 2006, EN 60079-11 : 2007, EN 60079-26 : 2007

Hazardous area  
Zone 0, 1, 2

T5:  $-40 \leq T_a \leq 60^\circ\text{C}$   
T6:  $-40 \leq T_a \leq 40^\circ\text{C}$

#### Terminal:

**41,42,43,44**  
U<sub>o</sub>: 9.6 VDC  
I<sub>o</sub>: 25 mA  
P<sub>o</sub>: 60 mW  
L<sub>o</sub>: 33 mH  
C<sub>o</sub>: 2.4 $\mu$ F

#### Terminal:

**51,52,53,54**  
U<sub>o</sub>: 9.6 VDC  
I<sub>o</sub>: 25 mA  
P<sub>o</sub>: 60 mW  
L<sub>o</sub>: 33 mH  
C<sub>o</sub>: 2.4 $\mu$ F

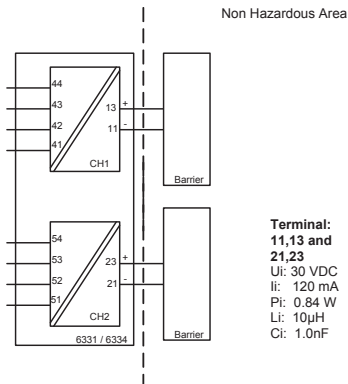

#### Terminal: 11,13 and 21,23

U<sub>i</sub>: 30 VDC  
I<sub>i</sub>: 120 mA  
P<sub>i</sub>: 0.84 W  
L<sub>i</sub>: 10 $\mu$ H  
C<sub>i</sub>: 1.0nF

#### Installation notes.

The sensor circuit is not infallibly galvanic isolated from the input circuit. However, the galvanic isolation between the circuits is capable of withstanding a test voltage of 500Vac during 1 minute.





**Displays** Programmable displays with a wide selection of inputs and outputs for display of temperature, volume and weight, etc. Feature linearization, scaling, and difference measurement functions for programming via PReset software.



**Ex interfaces** Interfaces for analog and digital signals as well as HART® signals between sensors / I/P converters / frequency signals and control systems in Ex zone 0, 1 & 2 and for some devices in zone 20, 21 & 22.



**Isolation** Galvanic isolators for analog and digital signals as well as HART® signals. A wide product range with both loop-powered and universal isolators featuring linearization, inversion, and scaling of output signals.



























**Temperature** A wide selection of transmitters for DIN form B mounting and DIN rail devices with analog and digital bus communication ranging from application-specific to universal transmitters.



**Universal** PC or front programmable devices with universal options for input, output and supply. This range offers a number of advanced features such as process calibration, linearization and auto-diagnosis.



- 
 [www.preelectronics.fr](http://www.preelectronics.fr)  
 [sales-fr@preelectronics.com](mailto:sales-fr@preelectronics.com)
- 
 [www.preelectronics.de](http://www.preelectronics.de)  
 [sales-de@preelectronics.com](mailto:sales-de@preelectronics.com)
- 
 [www.preelectronics.es](http://www.preelectronics.es)  
 [sales-es@preelectronics.com](mailto:sales-es@preelectronics.com)
- 
 [www.preelectronics.it](http://www.preelectronics.it)  
 [sales-it@preelectronics.com](mailto:sales-it@preelectronics.com)
- 
 [www.preelectronics.se](http://www.preelectronics.se)  
 [sales-se@preelectronics.com](mailto:sales-se@preelectronics.com)
- 
 [www.preelectronics.co.uk](http://www.preelectronics.co.uk)  
 [sales-uk@preelectronics.com](mailto:sales-uk@preelectronics.com)
- 
 [www.preelectronics.com](http://www.preelectronics.com)  
 [sales-us@preelectronics.com](mailto:sales-us@preelectronics.com)
- 
 [www.preelectronics.cn](http://www.preelectronics.cn)  
 [sales-cn@preelectronics.com](mailto:sales-cn@preelectronics.com)

## Head office

Denmark  
 PR electronics A/S  
 Lerbakken 10  
 DK-8410 Rønde

[www.preelectronics.com](http://www.preelectronics.com)  
[sales-dk@preelectronics.com](mailto:sales-dk@preelectronics.com)  
 tel. +45 86 37 26 77  
 fax +45 86 37 30 85



QUALITY SYSTEM AND ENVIRONMENTAL MANAGEMENT SYSTEM  
 DS/EN ISO 9001  
 DS/EN ISO 14001

